

Note: Items D and E should be attached to Post #1 prior to installation of Item H.

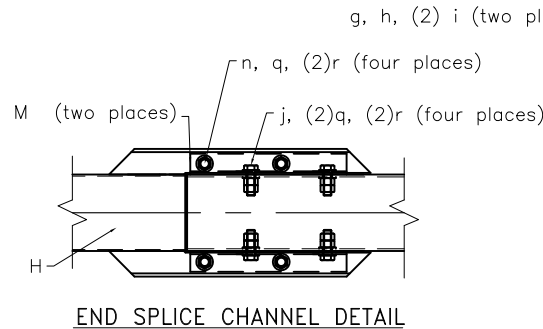

ITEM M SPLICE CHANNELS WILL SET ON THE TOP AND BOTTOM OF SECOND RAIL. THE BENT PLATES WELDED TO THE END OF ITEM H END TUBE RAIL WILL SET ON TOP OF ITEM M SPLICE CHANNELS

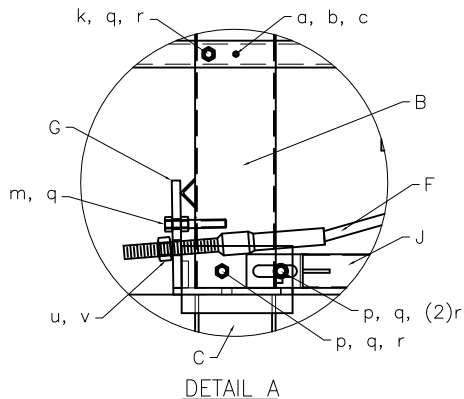
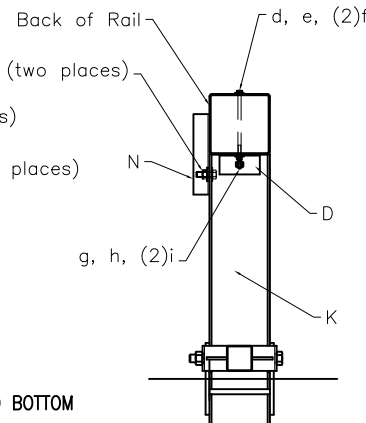

ITEM	QTY	DESCRIPTION	PART #
A	1	Box-Beam Impact Head	B3000
B	1	End Post Upper 6"x6"HSS (21 1/2")	MBEAT MP1A
C	1	End Post Lower W6x15x6'	MP1B
D	2	Support Bracket L 4"x2"x4"	BEAT-SB
E	1	Post Breaker	MBEAT-PB
F	1	Cable Anchor Assembly	E770
G	1	MASH Cable Anchor Bearing Plate	ME750
H	1	End Tube Rail 9'-10 3/4"	MBEAT ETR
J	1	Mash Ground Strut	MS785
K	1	MBEAT Hinge Post Top	MBEAT HP2A
L	1	Hinge Post Bottom	HP2B
M	2	End Section Splice Channel	BP-SC
N	1	Retention Plate C4x5.4 (Post #2)	MBEAT RP
HARDWARE			
a	1	1/4" x 3" Hex Bolt Grade 5	B140304A
b	1	1/4" Hex Nut	NO14
c	1	1/4" Washer	WO14
d	2	5/16" x 7" Hex Bolt Grade 5	B5160704A
e	2	5/16" Hex Nut	NO516
f	4	5/16" Washer	WO516
g	4	1/2" x 2" Hex Bolt A325	B120204A
h	4	1/2" Hex Nut	NO12A
i	8	1/2" Washer	WO12
j	4	5/8" x 2" Hex Bolt Grade 5	B580204A
k	1	5/8" x 3" Hex Bolt Grade 5	B580304A
m	1	5/8" x 5" Grade A449	B580504A
n	4	5/8" x 6" Hex Bolt Grade 5	B580604A
p	2	5/8" x 9" Hex Bolt Grade 5	B580904A
q	16	5/8" Hex Nut	NO55
r	20	5/8" Washer	WO50
s	1	3/4" x 8 1/2" Hex Bolt Grade 5	B340854A
t	1	3/4" Hex Nut	NO30
u	2	1" Hex Nut	N100
v	2	1" Washer	W100

GENERAL NOTES:

- All bolts, nuts, cable assemblies, cable anchors and bearing plates shall be galvanized.
- The lower sections of the Posts 1&2 shall not protrude more than 4 in [100] above the ground (measured along a 5' [1.5m] cord longitudinal to the system). Site grading may be necessary to meet this requirement.
- The lower section of the hinged post should not be driven with the upper post attached. If the post is placed in a drilled hole, the backfill material must be satisfactorily compacted to prevent settlement.
- When competent rock is encountered, a 12" [300] Ø post hole, 20 in. [500] deep cored into the rock surface may be used if approved by the engineer for Posts 1 and/or 2. Granular material will be placed in the bottom of the hole, approximately 2.5" [60] deep to provide drainage. The first and/or second post can be field cut to length, placed in the hole and backfilled with suitable backfill. The soil plate may be trimmed if required.
- The breakaway cable assembly must be taut. A locking device (vice grips or channel lock pliers) should be used to prevent the cable from twisting when tightening nuts.



MBEAT Terminal
Test Level 3

Drawing Name: MBEAT

Scale: None

Sheet: 1
Date: 07/09/20
By: JRR
Rev: 0