

(LOOP CABLE TIES (ITEM z) THROUGH HOLES IN GUSSET)

**IMPACT HEAD  
DETAIL**  
(2 PLACES)

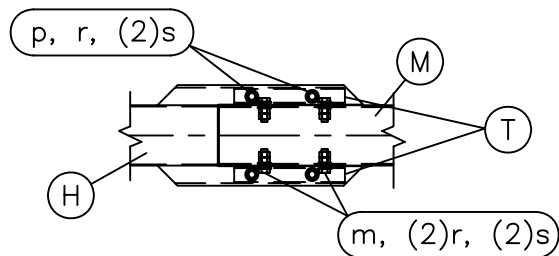

**END SPLICE DETAIL**  
(2 PLACES)

ITEM T SPLICE CHANNELS WILL SET ON THE TOP AND BOTTOM OF ITEM M SECOND RAIL. THE BENT PLATES WELDED TO THE END OF ITEM H END TUBE RAIL WILL SET ON TOP OF ITEM T SPLICE CHANNELS

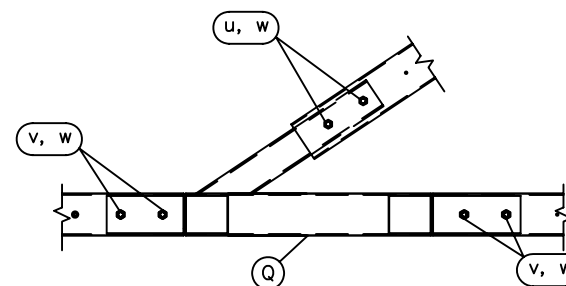

**"Y" CONNECTION DETAIL**  
(2 PLACES)

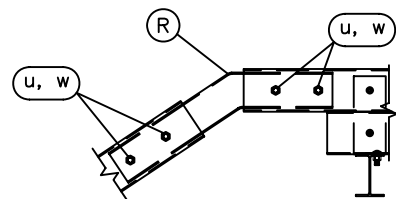

**BENT SPLICE DETAIL**  
(2 PLACES)

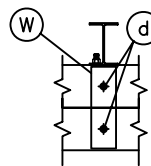

**TIE PLATE DETAIL**  
(24 PLACES)

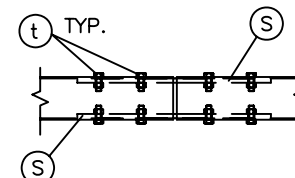

**INTERNAL SPLICE DETAIL**  
(8 PLACES)

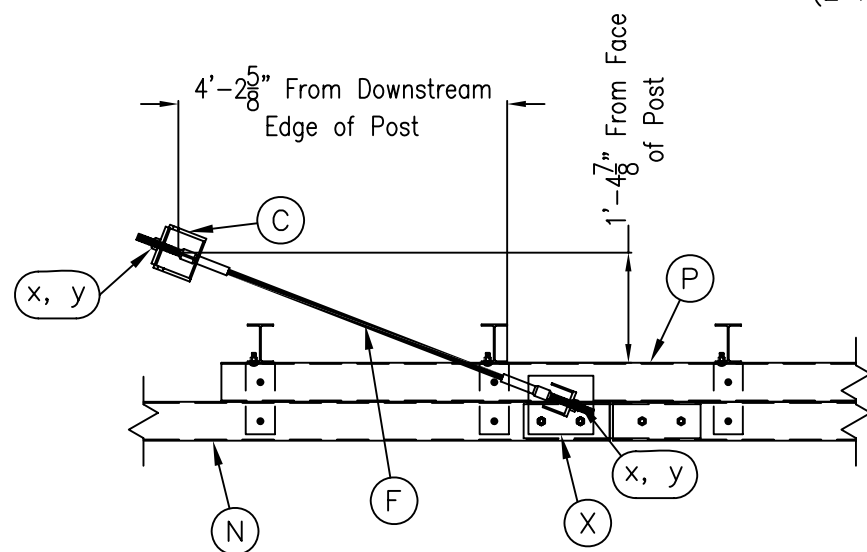

**ANCHOR DETAIL**  
(2 PLACES)

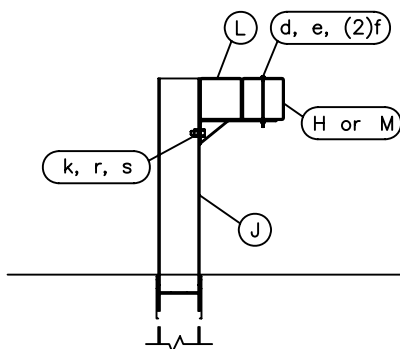
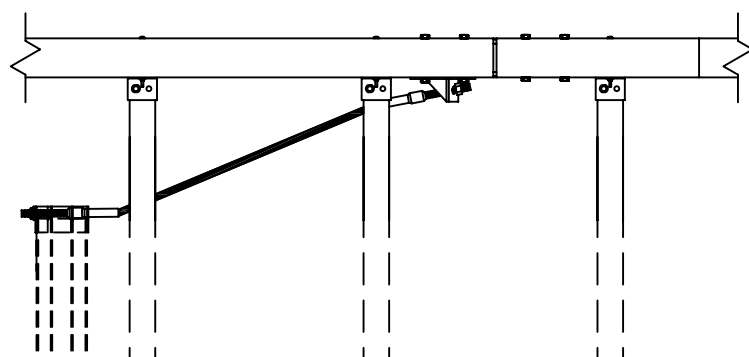

**END TERMINAL POSTS**  
POSTS 2 THRU 6  
(10 PLACES TOTAL)

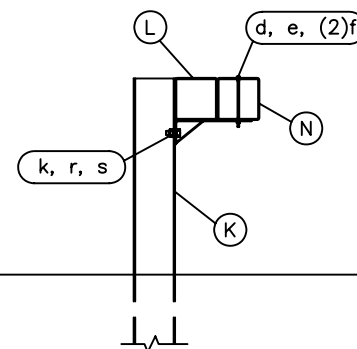

**LINE POSTS Without  
Extended Block (P)**  
POSTS 7, 8, 13-15, 20-22, 27, 28  
(20 PLACES TOTAL)

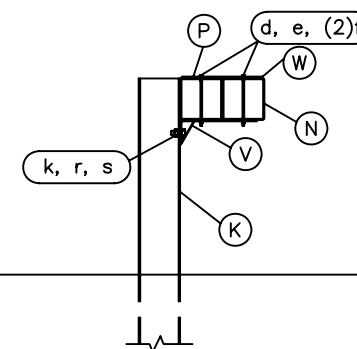

**LINE POSTS With  
Extended Block (P)**  
POSTS 9-12, 16-19, 23-26  
(24 PLACES TOTAL)

ITEM	QTY	DESCRIPTION
A	2	Box-Beam Impact Head
B	2	Upper End Post W6x9# x 21 1/2"
C	4	Lower End Post W6x15# x 8'-0"
D	2	Support Bracket L 4" x 2" x 4" LG.
E	2	Post Breaker Welded TS 2" x 2" x 1/4"
F	4	Cable Anchor Assembly
G	2	Cable Anchor Bearing Plate
H	2	End Tube Rail 8'-0" LG. x 1/8" THICK
J	10	Steel Breakaway Post W6x9# x 6'-0"
K	44*	Standard Steel Post W6x9# x 6'-0"
L	30*	Support Bracket TS 6" x 6" w/ Bent PL.
M	2	Second Rail 16'-2 1/2" LG.
N	12*	BP-Rail Section 11' - 11 1/2" LG.
P	6*	Extended Block 10' LG.
Q	2	"Y" Connection
R	2	Bent Splice
S	16*	Box Beam Splice Plates w/Nuts (2 per splice)
T	4	End Section Splice Channel Bent PL.
U	2	3/8" GALV. Cable 20' LG.
V	24*	Support Bracket
W	24*	Tie Plate
X	2	Anchor Plate
HARDWARE		
a	2	1/4" x 3" Hex Bolt
b	2	1/4" Hex Nut
c	4	1/4" Washer
d	80*	5/16" x 7 1/2" Hex Bolt Grade 5
e	80*	5/16" Hex Nut
f	160*	5/16" Washer
g	2	1/2" x 2" Hex Bolt Grade 2
h	2	1/2" x 5" Hex Bolt Grade 5
i	4	1/2" Hex Nut
j	4	1/2" Washer
k	54*	5/8" x 1 1/2" Hex Bolt Grade 5
m	8	5/8" x 2 1/2" Hex Bolt Grade 5
n	2	5/8" x 3" Hex Bolt Grade 5
p	8	5/8" x 6" Hex Bolt Grade 5
q	2	5/8" x 8" Hex Bolt Grade 5
r	82*	5/8" Hex Nut
s	90*	5/8" Washer
t	64*	3/4" x 2" Hex Bolt Grade 5
u	12	3/4" x 7" Hex Bolt Grade 5
v	8	3/4" x 8" Hex Bolt Grade 5
w	20	3/4" Hex Nut
x	8	1" Hex Nut Grade 5
y	8	1" Washer Grade 5
z	4	Cable Tie

\* QUANTITY VARIES DEPENDING ON PIER SPACING



BEAT BRIDGE PIER  
PROTECTION SYSTEM  
  
SYSTEM DETAILS AND  
PARTS LIST

Sheet:  
**S2**  
Date:  
05/24/06  
By:  
JRR

Drawing Name: BEAT-BP-3P  
Scale: NONE