

PLAN

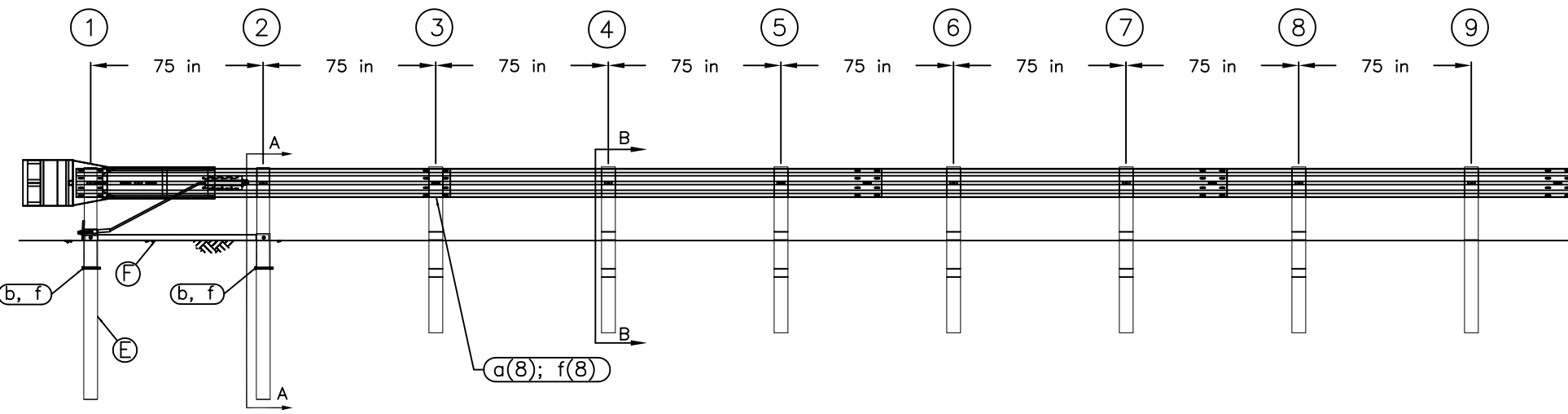

ELEVATION

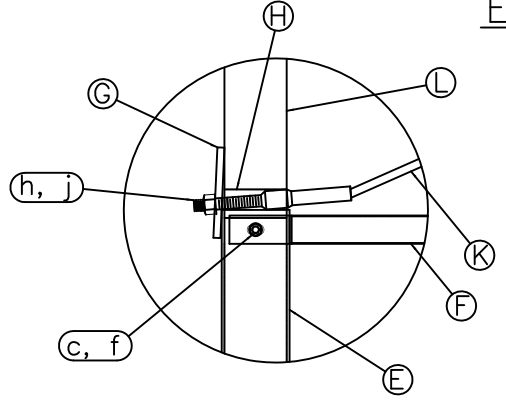

POST #1 CONNECTION DETAIL

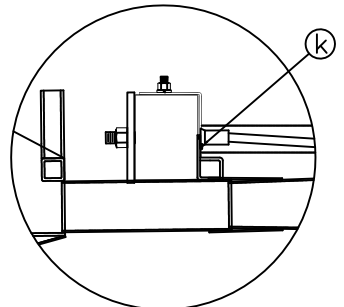

IMPACT HEAD CONNECTION DETAIL

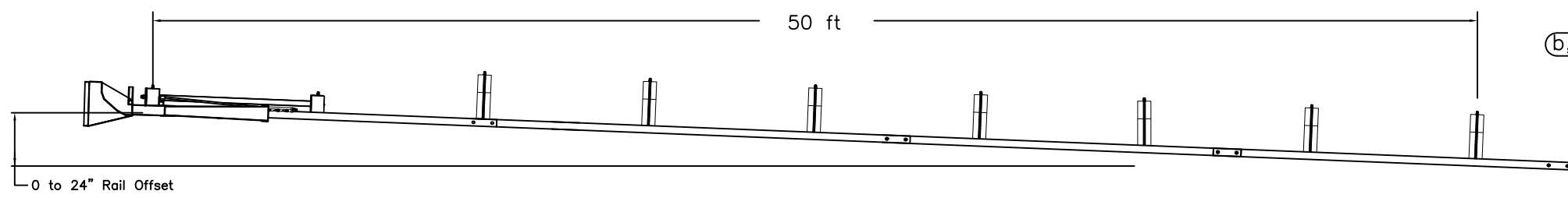

OPTIONAL FLARED INSTALLATION

25:1 maximum flare rate

- GENERAL NOTES:
1. Breakaway posts are required with the SKT.
 2. All bolts, nuts, cable assemblies, cable anchors and bearing plates shall be galvanized.
 3. The SKT can be flared at a rate of up to 25:1 to prevent the impact head from encroaching on the shoulder.
 4. The foundation tubes shall not protrude more than 4" above the ground (measured along a 5' cord). Site grading may be necessary to meet this requirement.
 5. When rock is encountered, a 12" Ø post hole, 20" into the rock surface may be used if approved by the engineer. Granular material will be placed in the bottom of the hole, approximately 2.5" deep to provide drainage. The first two posts can be field cut to length, placed in the hole and backfilled with adequately compacted material excavated from the hole.
 6. The breakaway cable assembly must be taut. A locking device (vice grips or channel lock pliers) should be used to prevent the cable from twisting when tightening nuts.
 7. A site evaluation should be considered if there is less than 25' between the outlet side of the terminal and any adjacent driving lane.
 8. The soil tubes may be driven with an approved driving head. They shall not be driven with the post in the tube.
 9. The wood blockouts should be "toe-nailed" to the rectangular wood posts to prevent them from turning when the wood shrinks.

ITEM	QTY	BILL OF MATERIALS	ITEM NO.
A	1	IMPACT HEAD	S3000
B	1	W-BEAM END SECTION, 12'-6", 12 Ga.	S1303
C	1	W-BEAM MGS, 15'-7 1/2", 12 Ga.	G1507
D	2	W-BEAM MGS, 12'-6", 12 Ga.	G1203A
E	2	FOUNDATION TUBE	S730
F	1	GROUND STRUT	E780
G	1	BEARING PLATE	E750
H	1	PIPE SLEEVE	E740
J	1	CABLE ANCHOR BOX	S760
K	1	BCT CABLE ANCHOR ASSEMBLY	E770
L	2	BCT WOOD POST	UP650
M	6	CRT WOOD POST	UP671
O	6	MGS TIMBER BLOCKOUT OR EQUIV.	P676
HARDWARE (ALL DIMENSIONS IN INCHES)			
a	24	5/8Ø x 1 1/4 SPLICE BOLT	B580122
b	2	5/8Ø x 7 1/2 HEX BOLT	B580754
c	2	5/8Ø x 10 HEX BOLT	B581004
d	1	5/8Ø x 10 H.G.R. BOLT	B581002
e	6	5/8Ø x 22 H.G.R. BOLT	B582202
f	35	5/8Ø H.G.R. NUT	N050
g	7	H.G.R. WASHER	W050
h	2	1 ANCHOR CABLE HEX NUT	N100
j	2	1 ANCHOR CABLE WASHER	W100
k	2	3/8 x 3 LAG SCREW	E350
m	8	CABLE ANCHOR BOX SHOULDER BOLT	SB58A
n	8	1/2 A325 STRUCTURAL NUT	N055A
o	16	1 1/16 OD x 9/16 ID A325 STR. WASHER	W050A

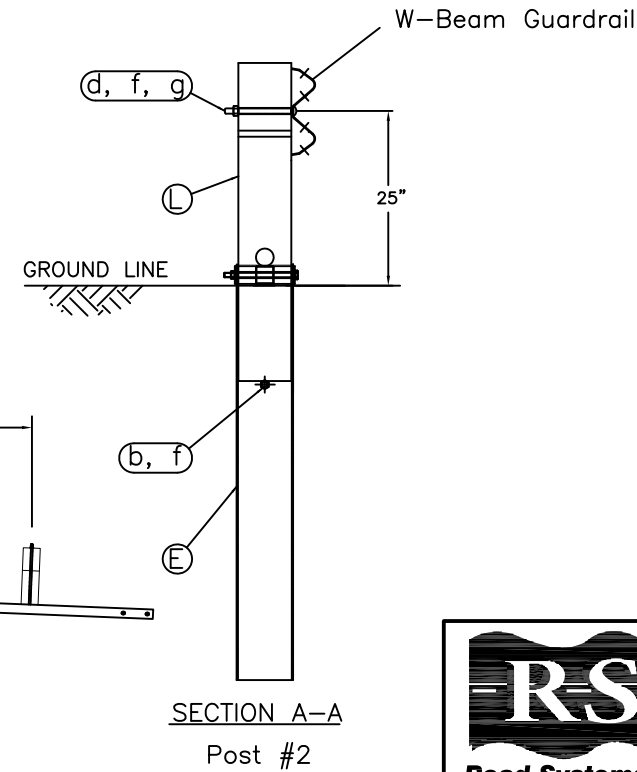

SECTION A-A
Post #2

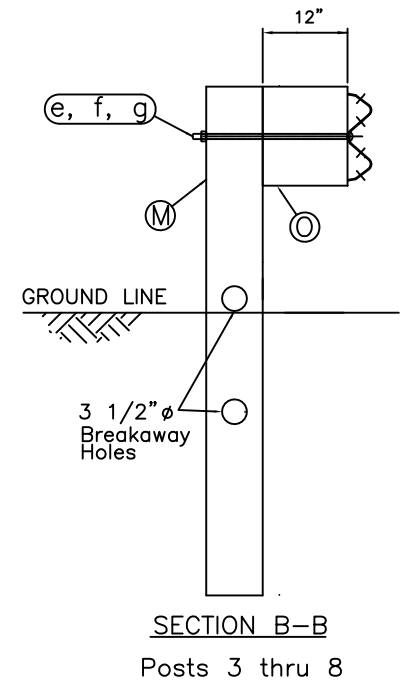

SECTION B-B
Posts 3 thru 8



Sequential Kinking Terminal SKT - Assembly		Sheet: A1
Midwest Guardrail System Standard End Rail Wood Post System		Date: 05/19/11
Drawing Name: SKT-MGS-W-ST-END		By: JRR
Scale: NONE		Rev: 0